

# SINGER®

## 2591 SERIES

### HIGH-SPEED LOCKSTITCH SEWING MACHINE

### ILLUSTRATED PARTS LIST



# CONTENTS

1. MACHINE FRAME AND MISCELLANEOUS COVER COMPONENTS.....	1
2. ARM SHAFT AND THREAD TAKE-UP LEVER COMPONENTS.....	3
3. NEEDLE BAR, UPRIGHT SHAFT AND ROTATING HOOK DRIVING SHAFT COMPONENTS ....	5
4. PRESSER FOOT COMPONENTS.....	7
5. FEED MECHANISM COMPONENTS.....	9
6. LUBRICATION COMPONENTS.....	11
7. OIL PAN COMPONENTS.....	13
8. BELT COVER, BOBBIN WINDER AND THREAD STAND COMPONENTS.....	15
9. ACCESSORY PARTS.....	17

# 1. MACHINE FRAME AND MISCELLANEOUS COVER COMPONENTS

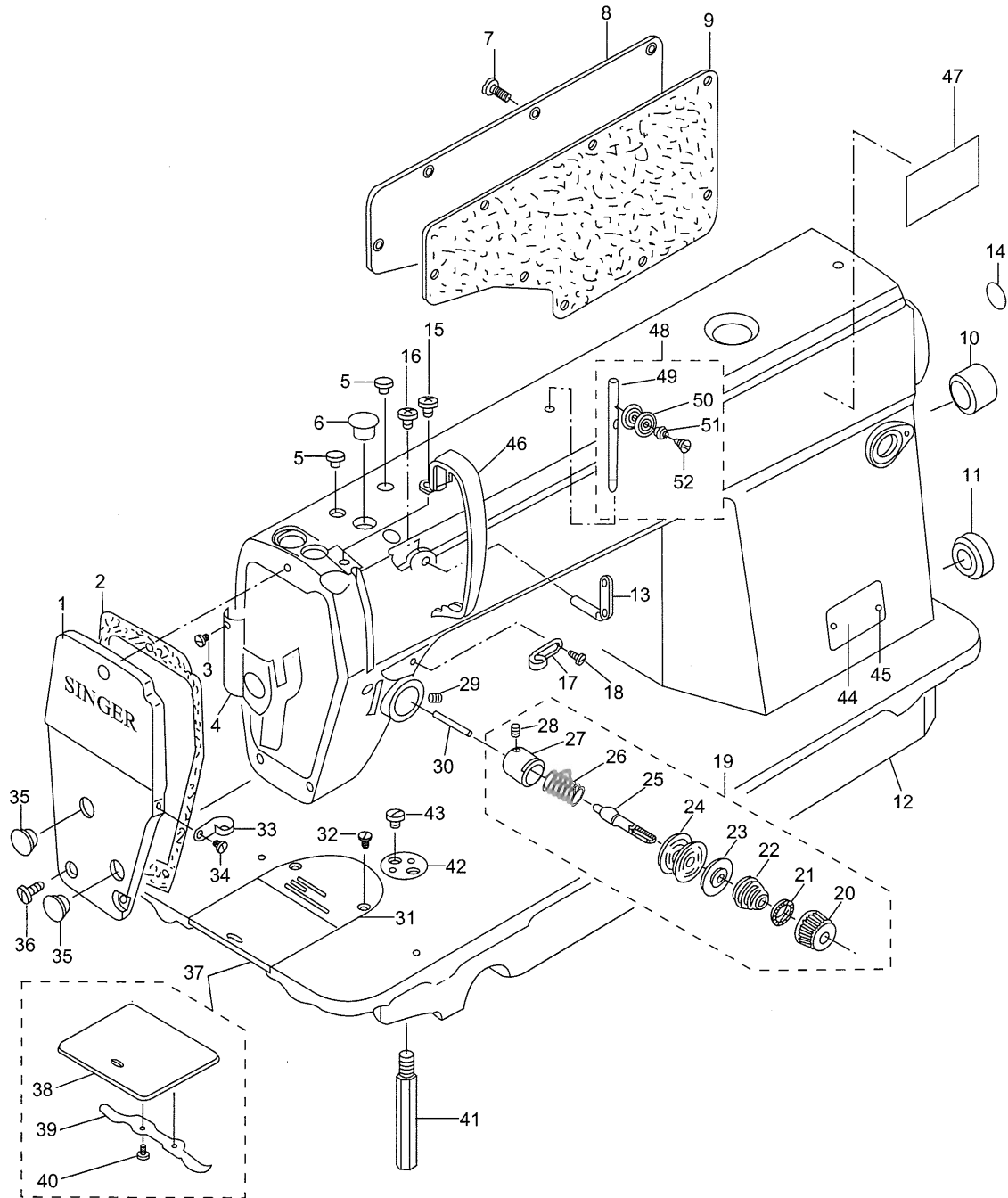

# 1. MACHINE FRAME AND MISCELLANEOUS COVER COMPINENTS

No.	P/N	DESCRIPTION	QTY	2 0 0 A	3 0 0 A	3 0 8 A	5 0 8 A
1	IP16004	FACE PLATE	1	☆	☆	☆	☆
2	IP04002	FACE PLATE GASKET	1	☆	☆	☆	☆
3	IP12002	SCREW SM1/8"x44 L=4	1	☆	☆		
	IP12223	SCREW SM1/8"x44 L=2.5	1			☆	☆
4	IP04003	ARM OIL SHIFLD ASM.	1	☆	☆	☆	☆
5	IP07001	RUBBER PLUG	2	☆	☆	☆	☆
6	IP07002	RUBBER PLUG	1	☆	☆	☆	☆
7	IP12004	SCREW SM3/16"x28 L=9	8	☆	☆	☆	☆
8	IP04004	SIDE PLATE	1	☆	☆	☆	☆
9	IP04005	SIDE PLATE GASKET	1	☆	☆	☆	☆
10	IP07003	RUBBER PLUG	1	☆	☆	☆	☆
11	IP07004	RUBBER PLUG	1	☆	☆	☆	☆
12	IP16002	FRAME	1	☆	☆	☆	☆
13	IP04007	TWO-HOLE THREAD EYELET	1	☆	☆	☆	☆
14	IP03020	EARTHING MARK	1	☆	☆	☆	☆
15	IP12005	SCREW SM3/16"x28 L=6	1	☆	☆	☆	☆
16	IP12006	SCREW SM3/16"x28 L=6	1	☆	☆	☆	☆
17	IP04008	RIGHT ARM THREAD GUIDE	1	☆	☆	☆	☆
18	IP12007	SCREW SM11/64"x40 L=6	1	☆	☆	☆	☆
19	IP17006	THREAD TENSION REGULATOR	1	☆	☆	☆	☆
20	IP12008	TENSION ADJUSTING NUT	(1)	☆	☆	☆	☆
21	IP04009	ROTATING STOPPER	(1)	☆	☆	☆	☆
22	IP10001	TENSION SPRING A	(1)	☆	☆		
	IP10002	TENSION SPRING A	(1)			☆	☆
23	IP04010	TENSION DISK PRESSER	(1)	☆	☆	☆	☆
24	IP04011	THREAD TENSION DISK	(2)	☆	☆	☆	☆
25	IP08001	TENSION POST	(1)	☆	☆	☆	☆
26	IP10003	TAKE-UP SPRING	(1)	☆	☆	☆	☆
27	IP08002	TENSION POST SOCKET	(1)	☆	☆	☆	☆
28	IP12009	SCREW SM9/64"x40 L=5.5	(1)	☆	☆	☆	☆
29	IP12010	SCREW SM15/64"x28 L=7	1	☆	☆	☆	☆
30	IP04012	TENSION RELEASING PIN	1	☆	☆	☆	☆
31	IP04079	THROAT PLATE	1	☆			
	IP04013	THROAT PLATE	1		☆		
	IP04014	THROAT PLATE	1			☆	☆
32	IP12011	SCREW SM11/64"x40 L=8.5	2	☆	☆	☆	☆
33	IP04015	LEFT ARM THREAD GUIDE	1	☆	☆	☆	☆
34	IP12012	SCREW SM11/64"x40 L=6	1	☆	☆	☆	☆
35	IP07005	RUBBER PLUG	2	☆	☆	☆	☆
36	IP12013	SCREW SM3/16"x28 L=9	3	☆	☆	☆	☆
37	IP17007	SLIDE ASM.	1	☆	☆	☆	☆
38	IP04016	SLIDE PLATE	(1)	☆	☆	☆	☆
39	IP04017	SLIDE SPRING	(1)	☆	☆	☆	☆
40	IP12014	SCREW SM3/32"x56 L=1.9	(2)	☆	☆	☆	☆
41	IP08003	SCREW STUD	4	☆	☆	☆	☆
42	IP04018	SULER STOPPER	1	☆	☆	☆	☆
43	IP12015	SCREW SM11/64"x40 L=5	2	☆	☆	☆	☆
44	IP03011-002	MODEL NO. LABEL	1	☆			
	IP03011-001	MODEL NO. LABEL	1		☆		
	IP03011-003	MODEL NO. LABEL	1			☆	
	IP03011-004	MODEL NO. LABEL	1				☆
45	IP12016	MODEL NO. LABEL RIVET	2	☆	☆	☆	☆
46	IP04019	THREAD TAKE-UP LEVER COVER	1	☆	☆		
	IP04020	THREAD TAKE-UP LEVER COVER	1			☆	☆
47	IP03024	SAFETY LABEL	1	☆	☆	☆	☆
48	IP17005	THREAD GUIDE ROD ASM.	1	☆	☆	☆	☆
49	IP04077	THREAD GUIDE ROD	(1)	☆	☆	☆	☆
50	IP04078	TENSION DISK	(2)	☆	☆	☆	☆
51	IP10022	TENSION SPRING	(1)	☆	☆	☆	☆
52	IP12136	HINGE SCREW	(1)	☆	☆	☆	☆

## 2. ARM SHAFT AND THREAD TAKE-UP LEVER COMPONENTS

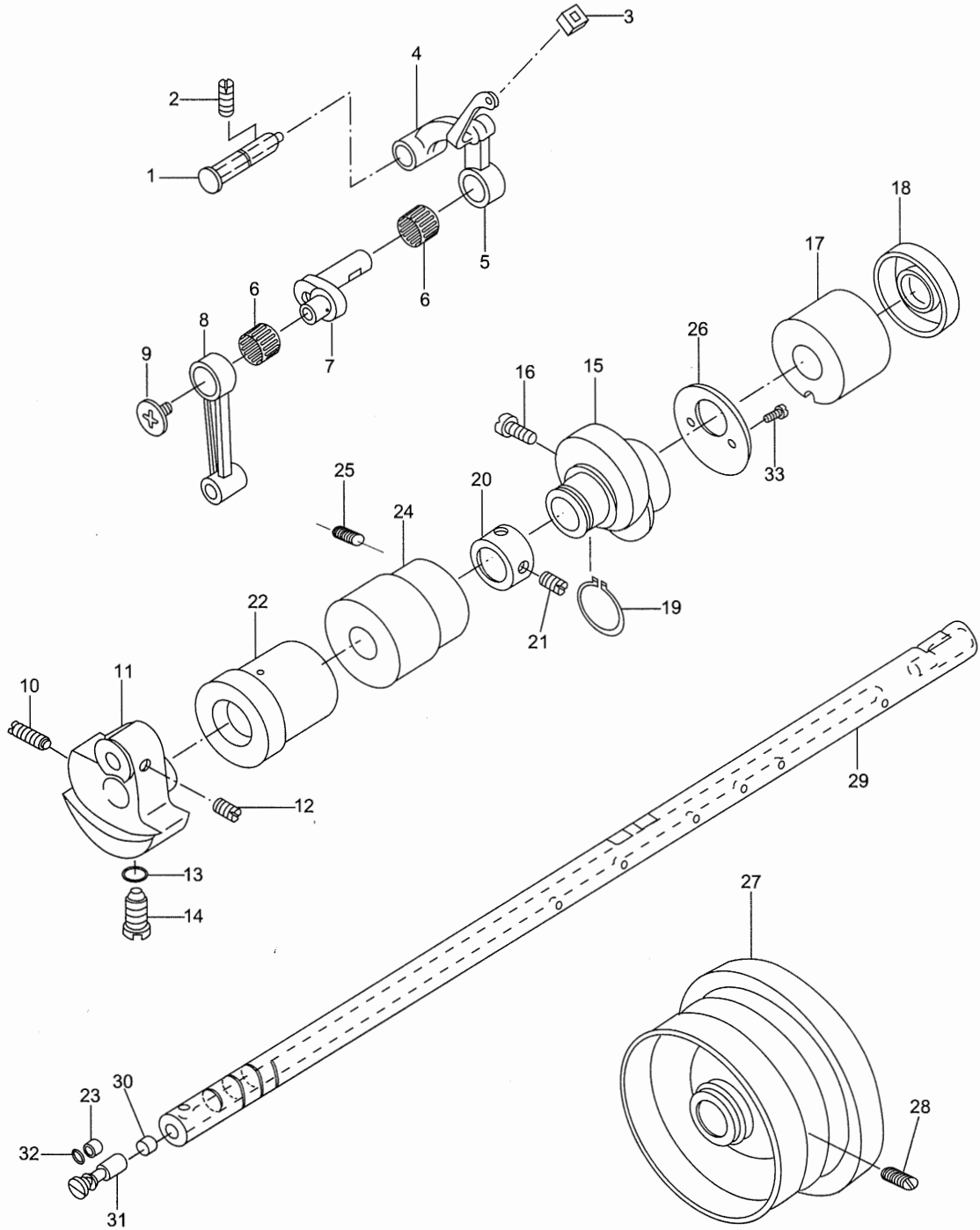

## 2. ARM SHAFT AND THREAD TAKE-UP LEVER COMPONENTS

No.	P/N	DESCREPTION	QTY	2 0 0 A	3 0 0 A	3 0 8 A	5 0 8 A
1	IP08004	THREAD TAKE-UP CRANK SHAFT ASM.	1	☆	☆		
	IP08005	THREAD TAKE-UP CRANK SHAFT ASM.	1			☆	☆
2	IP12017	SCREW SM15/64"x28 L=10.5	1	☆	☆	☆	☆
3	IP07006	RUBBER	1	☆	☆	☆	☆
4	IP04021	THREAD TAKE-UP SWING ROD	1	☆	☆		
	IP04022	THREAD TAKE-UP SWING ROD	1			☆	☆
5	IP17008	THREAD TAKE-UP LEVER	1	☆	☆		
	IP17009	THREAD TAKE-UP LEVER	1			☆	☆
6	IP12018	NEEDLE BEARING	2	☆	☆	☆	☆
7	IP08006	NEEDLE BAR CRANK	1	☆	☆		
	IP08007	NEEDLE BAR CRANK	1			☆	☆
8	IP05001	NEEDLE BAR CRANK ROD	1	☆	☆	☆	☆
9	IP12019	SCREW SM9/64"x40 L=4.8	1	☆	☆	☆	☆
10	IP12020	SCREW SM9/32"x28 L=16	1	☆	☆	☆	☆
11	IP05002	COUNTER WEIGHT	1	☆	☆		
	IP05003	COUNTER WEIGHT	1			☆	
	IP08102	COUNTER WEIGHT	1				☆
12	IP12021	SCREW SM1/4"x40 L=6	2	☆	☆	☆	☆
13	IP12022	RUBBER RING	1	☆	☆	☆	☆
14	IP12023	SCREW SM9/32"x28 L=6	1	☆	☆	☆	☆
15	IP08008	FEED DRIVE ECCENTRIC CAM.	1	☆	☆		
	IP08009	FEED DRIVE ECCENTRIC CAM.	1			☆	☆
16	IP12024	SCREW SM1/4"x40 L=11	2	☆	☆	☆	☆
17	IP08010	ARM SHAFT BUSHING, REAR	1	☆	☆	☆	☆
18	IP07007	OIL SEAL	2	☆	☆	☆	☆
19	IP12025	SNAP RING	1	☆	☆	☆	☆
20	IP08011	THRUST COLLAR	1	☆	☆	☆	☆
21	IP12026	SCREW SM1/4"x40 L=6	2	☆	☆	☆	☆
22	IP08012	FRONT BUSHING	1	☆	☆	☆	☆
23	IP12027	OIL ADJUSTING COLLAR	1	☆	☆	☆	☆
24	IP08013	BUSHING, MIDDLE	1	☆	☆	☆	☆
25	IP12028	SCREW	1	☆	☆	☆	☆
26	IP04023	THRUST COLLAR	1	☆	☆		
	IP04024	THRUST COLLAR	1			☆	☆
27	IP05004	HAND WHEEL	1	☆	☆	☆	
	IP05040	HAND WHEEL	1				☆
28	IP12029	SCREW SM15/64"x28 L=15	2	☆	☆	☆	☆
29	IP08014	ARM SHAFT	1	☆	☆	☆	☆
30	IP18002	ROLLER FELT	1	☆	☆	☆	☆
31	IP08015	OIL AMOUNT ADJUSTING PIN	1	☆	☆	☆	☆
32	IP07008	RUBBER RING	1	☆	☆	☆	☆
33	IP12030	SCREW SM9/64"x40 L=6	2	☆	☆	☆	☆

### 3. NEEDLE BAR, UPRIGHT SHAFT AND ROTATING HOOK DRIVING SHAFT COMPONENTS

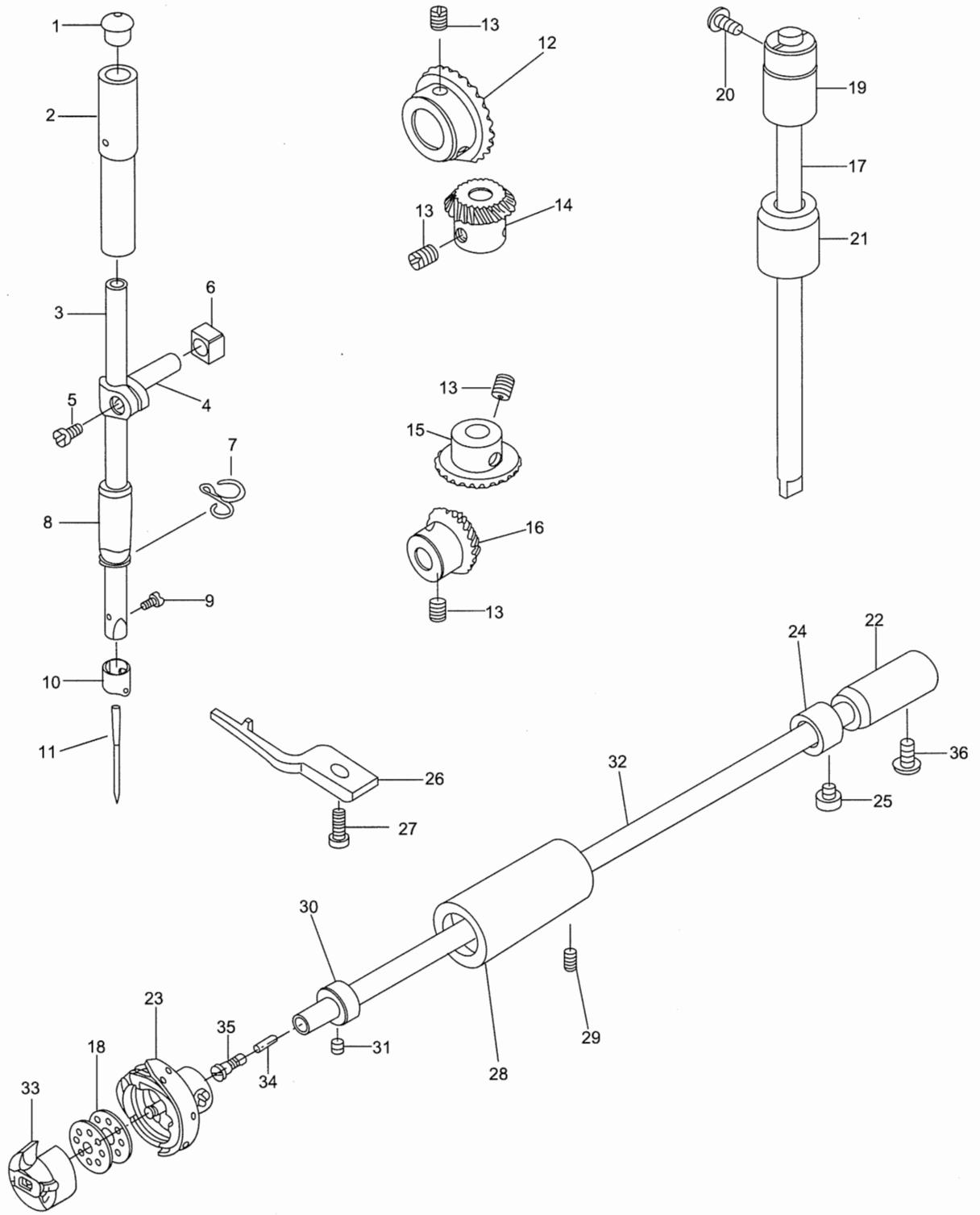

From the library of: Diamond Needle Corp



### 3. NEEDLE BAR, UPRIGHT SHAFT AND ROTATING HOOK DRIVING SHAFT COMPONENTS

No.	P/N	DESCRIPTION	QTY	200A	300A	308A	508A
1	IP07009	CAP	1	☆	☆	☆	☆
2	IP08016	NEEDLE BAR BUSHING, UPPER	1	☆	☆	☆	☆
3	IP08108	NEEDLE BAR	1	☆	☆	☆	☆
4	IP08019	NEEDLE BAR HOLDER	1	☆	☆	☆	☆
5	IP12031	SCREW SM9/64"x40 L=6	1	☆	☆	☆	☆
6	IP06001	SLIDING BLOCK	1	☆	☆	☆	☆
7	IP10004	NEEDLE BAR THREAD GUIDE	1	☆	☆		
	IP10005	NEEDLE BAR THREAD GUIDE	1			☆	☆
8	IP08020	NEEDLE BAR BUSHING, LOWER	1	☆	☆		
	IP08021	NEEDLE BAR BUSHING, LOWER	1			☆	☆
9	IP12032	SCREW SM1/8"x44 L=4.5	1	☆	☆	☆	☆
10	IP04025	NEEDLE BAR THREAD GUIDE	1	☆	☆		
	IP04026	NEEDLE BAR THREAD GUIDE	1			☆	☆
11	1955-01 size14	NEEDLE	1	☆			
	1955-01 size16	NEEDLE	1		☆		
	1955-01 size21	NEEDLE	1			☆	☆
12	IP08022	GEAR	1	☆	☆	☆	☆
13	IP12033	SCREW SM1/4"x40 L=8	8	☆	☆	☆	☆
14	IP08023	PINION	1	☆	☆	☆	☆
15	IP08024	GEAR. LARGE	1	☆	☆	☆	☆
16	IP08025	PINION	1	☆	☆	☆	☆
17	IP08026	UPRIGHT SHAFT	1	☆	☆	☆	
	IP08103	UPRIGHT SHAFT	1				☆
18	IP04027	BOBBIN	1	☆	☆		
	IP04028	BOBBIN	1			☆	☆
19	IP08027	UPRIGHT SHAFT BUSHING, UPPER	1	☆	☆	☆	☆
20	IP12034	SCREW SM3/16"x28 L=9	1	☆	☆	☆	☆
21	IP08028	UPRIGHT SHAFT BUSHING, LOWER	1	☆	☆	☆	☆
22	IP08029	BUSHING, REAR	1	☆	☆	☆	☆
23	IP08030	ROTATING HOOK	1	☆	☆	☆	
	IP08106	ROTATING HOOK	1				☆
24	IP08031	THRUST COLLAR	1	☆	☆	☆	☆
25	IP12035	SCREW SM11/64"x40 L=4.8	2	☆	☆	☆	☆
26	IP04029	POSITIONING FINGER	1	☆	☆		
	IP04030	POSITIONING FINGER	1			☆	☆
27	IP12036	SCREW SM11/64"x40 L=9.5	1	☆	☆	☆	☆
28	IP08032	HOOK SHAFT FRONT BUSHING	1	☆	☆	☆	
	IP08104	HOOK SHAFT FRONT BUSHING	1				☆
29	IP12037	SCREW	1	☆	☆		
	IP12038	SCREW	1			☆	☆
30	IP08033	THRUST COLLAR	1	☆	☆	☆	☆
31	IP12039	SCREW SM11/64"x40 L=3.5	2	☆	☆	☆	☆
32	IP08034	HOOK SHAFT	1	☆	☆	☆	
	IP08105	HOOK SHAFT	1				☆
33	IP08035	BOBBIN CASE	1	☆	☆	☆	
	IP08107	BOBBIN CASE	1				☆
34	IP18003	OIL WICK	1	☆	☆	☆	☆
35	IP12040	OIL SEAL SCREW	1	☆	☆	☆	☆
36	IP12041	SCREW SM3/16"x28 L=12	1	☆	☆	☆	☆

# 4. PRESSER FOOT COMPONENTS

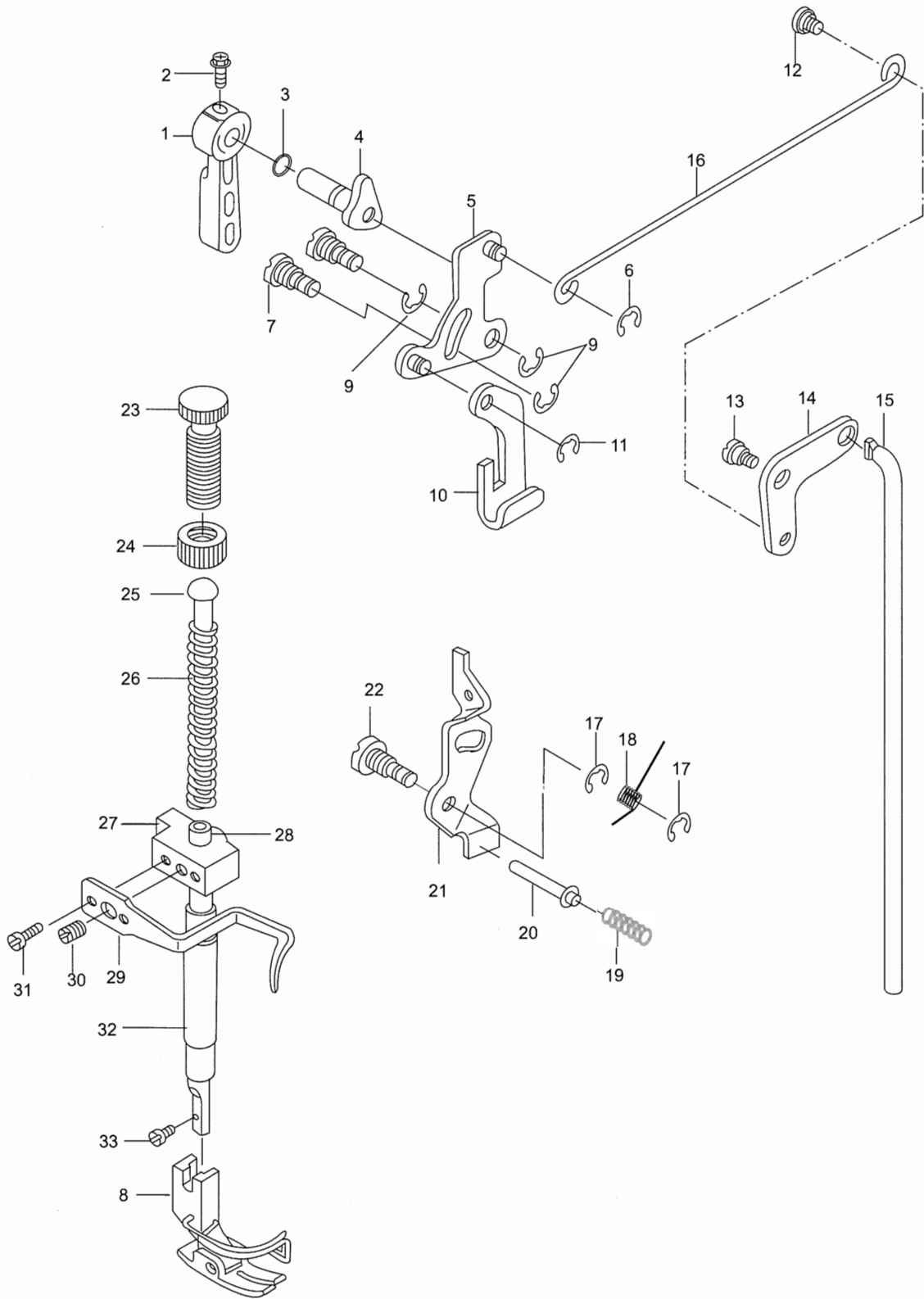

From the library of: Diamond Needle Corp

#### 4. PRESSER FOOT COMPONENTS

No.	P/N	DESCRIPTION	QTY	2 0 0 A	3 0 0 A	3 0 8 A	5 0 8 A
1	IP07010	HAND LIFTER	1	☆	☆	☆	☆
2	IP12042	SCREW SM9/64"x40 L=9.5	1	☆	☆	☆	☆
3	IP07011	RUBBER RING	1	☆	☆	☆	☆
4	IP04031	HAND LIFTER CAM ASM.	1	☆	☆	☆	☆
5	IP04032	HAND LIFTER LINK	1	☆	☆	☆	☆
6	IP12043	SNAP RING	1	☆	☆	☆	☆
7	IP12044	LINK SHAFT	2	☆	☆	☆	☆
8	IP17033	PRESSER FOOT ASM.	1	☆			
	IP17010	PRESSER FOOT ASM.	1		☆		
	IP17011	PRESSER FOOT ASM.	1			☆	☆
9	IP12045	SNAP RING	3	☆	☆	☆	☆
10	IP04033	LIFTING LEVER	1	☆	☆	☆	☆
11	IP12046	SNAP RING	1	☆	☆	☆	☆
12	IP12047	SCREW	1	☆	☆	☆	☆
13	IP12048	SCREW	1	☆	☆	☆	☆
14	IP04034	LIFTING LEVER LINK	1	☆	☆	☆	☆
15	IP04035	CONNECTING ROD VERTICAL	1	☆	☆	☆	☆
16	IP04036	LIFTING LEVER CONNECTING ROD	1	☆	☆	☆	☆
17	IP12049	SNAP RING	2	☆	☆	☆	☆
18	IP10006	TENSION RELEASE RETURN SPRING	1	☆	☆	☆	☆
19	IP10007	TENSION RELEASE PIN SPRING	1	☆	☆	☆	☆
20	IP04037	TENSION RELEASE SUPPORTING PIN	1	☆	☆	☆	☆
21	IP04038	TENSION RELEASE PLATE	1	☆	☆	☆	☆
22	IP12050	TENSION RELEASE SHAFT	1	☆	☆	☆	☆
23	IP12051	PRESURE ADJUSTING SCREW	1	☆	☆	☆	☆
24	IP12052	PRESURE ADJUSTING NUT	1	☆	☆	☆	☆
25	IP04039	GUIDE BAR	1	☆	☆	☆	☆
26	IP10008	SPRING	1	☆	☆		
	IP10009	SPRING	1			☆	☆
27	IP08036	PRESSER BAR GUIDE BRACKET	1	☆	☆	☆	☆
28	IP08037	PRESSER BAR	1	☆	☆	☆	☆
29	IP04040	PRESSER BAR THREAD GUIDE	1	☆	☆	☆	☆
30	IP12053	SCREW SM1/4"x40 L=8	1	☆	☆	☆	☆
31	IP12054	SCREW SM9/64"x40 L=8.5	2	☆	☆	☆	☆
32	IP12055	PRESSER BAR BUSHING, LOWER	1	☆	☆	☆	☆
33	IP12056	SCREW SM9/64"x40 L=10.5	1	☆	☆	☆	☆

# 5. FEED MECHANISM COMPONENTS

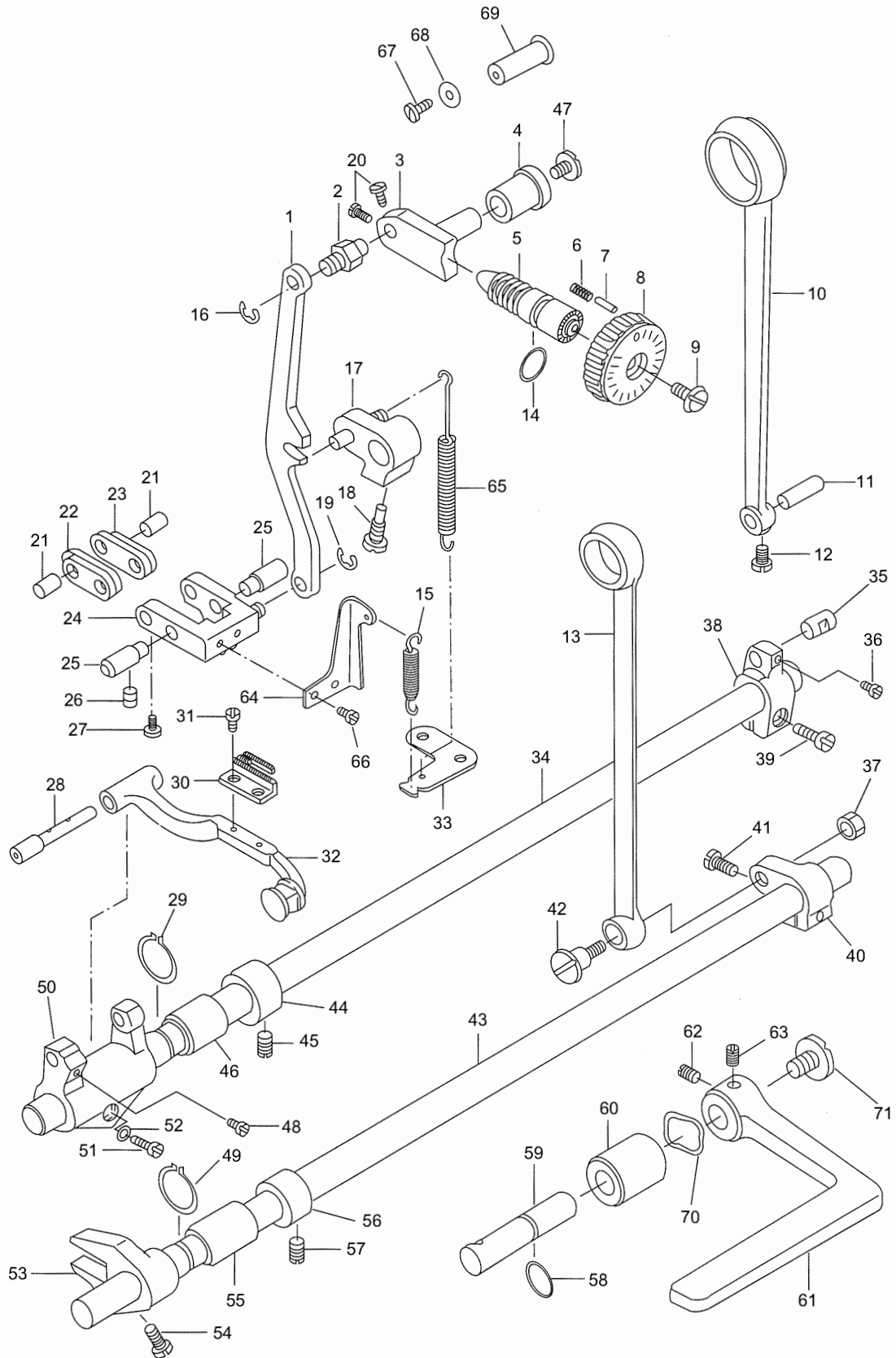

## 5. FEED MECHANISM COMPONENTS

No.	P/N	DESCRIPTION	QTY	2	3	3	5	No.	P/N	DESCRIPTION	QTY	2	3	3	5
				00	00	08	08					00	00	08	08
				A	A	A	A					A	A	A	A
1	IP04041	FEED ADJUST ROD	1	☆	☆			39	IP12070	SCREW SM3/16"x28 L=15.5	1	☆	☆	☆	☆
	IP04042	FEED ADJUST ROD	1			☆	☆	40	IP05014	LIFTING ROCKER	1	☆	☆	☆	☆
2	IP08038	FEED REGULATOR PIN	1	☆	☆			41	IP12071	SCREW SM3/16"x28 L=15.5	1	☆	☆	☆	☆
	IP08039	FEED REGULATOR PIN	1			☆	☆	42	IP12072	SCREW	1	☆	☆	☆	☆
3	IP08040	FEED REGULATOR	1	☆	☆			43	IP08053	FEED DRIVING SHAFT	1	☆	☆	☆	☆
	IP08041	FEED REGULATOR	1			☆	☆	44	IP12073	THRUST COLLAR	1	☆	☆	☆	☆
4	IP08042	FEED REGULATOR BUSHING	1	☆	☆	☆	☆	45	IP12074	SCREW SM1/4"x40 L=6	2	☆	☆	☆	☆
5	IP08043	SCREW	1	☆	☆	☆	☆	46	IP08054	FEED ROCKER SHAFT BUSHING	1	☆	☆	☆	☆
6	IP10010	SPRING	1	☆	☆	☆	☆	47	IP12075	SCREW SM3/16"x28 L=7	1	☆	☆	☆	☆
7	IP04043	PIN	1	☆	☆	☆	☆	48	IP12076	SCREW SM11/64"x40 L=7	1	☆	☆	☆	☆
8	IP07012	FEED DIAL	1	☆	☆			49	IP12077	RETAINING RING	1	☆	☆	☆	☆
	IP07013	FEED DIAL	1			☆	☆	50	IP05015	FEED BAR DRIVING CRANK	1	☆	☆		
9	IP12057	SCREW SM 3/16"x28 L=18	1	☆	☆	☆	☆		IP05016	FEED BAR DRIVING CRANK	1			☆	☆
10	IP05005	CONNECTING ROD	1	☆	☆			51	IP12078	SCREW SM3/16"x28 L=14	1	☆	☆	☆	☆
	IP05006	CONNECTING ROD	1			☆	☆	52	IP12079	WASHER	1	☆	☆	☆	☆
11	IP08044	PIN	1	☆	☆	☆	☆	53	IP05017	LIFTING FORK	1	☆	☆	☆	☆
12	IP12058	SCREW SM9/64"x40 L=6	1	☆	☆	☆	☆	54	IP12080	SCREW SM11/64"x40 L=10.5	1	☆	☆	☆	☆
13	IP05007	CONNECTING ROD	1	☆	☆	☆	☆	55	IP08055	FEED ROCKER SHAFT BUSHING	1	☆	☆	☆	☆
14	IP07014	RUBBER RING	1	☆	☆	☆	☆	56	IP12081	THRUST COLLAR	1	☆	☆	☆	☆
15	IP10011	SPRING	1	☆	☆			57	IP12082	SCREW SM1/4"x40 L=6	2	☆	☆	☆	☆
	IP10012	SPRING	1			☆	☆	58	IP08056	RUBBER RING	1	☆	☆	☆	☆
16	IP12059	SNAP RING	1	☆	☆	☆	☆	59	IP08057	REVERSE FEED SHAFT	1	☆	☆	☆	☆
17	IP17012	REVERSE FEED ARM ASM.	1	☆	☆				IP08058	REVERSE FEED SHAFT	1	☆	☆	☆	☆
	IP17013	REVERSE FEED ARM ASM.	1			☆	☆	60	IP08059	BUSHING	1	☆	☆	☆	☆
18	IP12060	SCREW	1	☆	☆			61	IP05018	REVERSE FEED CONTROL LEVER	1	☆	☆	☆	☆
	IP12061	SCREW	1			☆	☆	62	IP12083	SCREW SM1/4"x40 L=8	1	☆	☆	☆	☆
19	IP12062	SNAP RING	1	☆	☆	☆	☆	63	IP12084	SCREW SM1/4"x40 L=8	1	☆	☆	☆	☆
20	IP12063	SCREW SM9/64"x40 L=6	2	☆	☆	☆	☆	64	IP04048	ADJUSTING LINK SPRING GUIDE	1	☆	☆	☆	☆
21	IP08045	PIN	2	☆	☆	☆	☆	65	IP10013	REVERSE FEED SPRING	1	☆	☆		
22	IP04044	LINK	2	☆	☆	☆	☆		IP10014	REVERSE FEED SPRING	1			☆	☆
23	IP04045	LINK	2	☆	☆	☆	☆	66	IP12085	SCREW SM11/64"x40 L=5	2	☆	☆	☆	☆
24	IP05008	FEED ADJUST LINK ASM.	1	☆	☆			67	IP12086	SCREW	1			☆	☆
	IP05009	FEED ADJUST LINK ASM.	1			☆	☆	68	IP12087	WASHER	1			☆	☆
25	IP08046	ADJUSTING LINK SHAFT	2	☆	☆	☆	☆	69	IP12088	FEED ADJUSTING SHAFT	1			☆	☆
26	IP12064	SCREW SM15/64"x28 L=7	2	☆	☆	☆	☆	70	IP12137	WASHER	1			☆	☆
27	IP12065	SCREW SM9/64"x40 L=6	2	☆	☆	☆	☆	71	IP12138	SCREW	1			☆	☆
28	IP08049	FEED BAR SHAFT	1	☆	☆										
	IP08050	FEED BAR SHAFT	1			☆	☆								
29	IP12066	RETAINING RING	1	☆	☆	☆	☆								
30	IP06012	FEED DOG	1	☆											
	IP06002	FEED DOG	1			☆									
	IP06003	FEED DOG	1			☆	☆								
31	IP12067	SCREW SM1/8"x44 L=6	2	☆	☆	☆	☆								
32	IP05010	FEED BAR ASM.	1	☆	☆										
	IP05011	FEED BAR ASM.	1			☆	☆								
33	IP04046	FEED SPRING HOOK	1	☆	☆										
	IP04047	FEED SPRING HOOK	1			☆	☆								
34	IP08051	FEED ROCKER SHAFT	1	☆	☆	☆	☆								
35	IP08052	PIN	1	☆	☆	☆	☆								
36	IP12068	SCREW SM9/64"x40 L=6	1	☆	☆	☆	☆								
37	IP12069	NUT SM9/32"x28	1	☆	☆	☆	☆								
38	IP05012	FEED ROCKER	1	☆	☆										
	IP05013	FEED ROCKER	1			☆	☆								

From the library of Dr. P. Sambandhaiah

# 6. LUBRICATION COMPONENTS

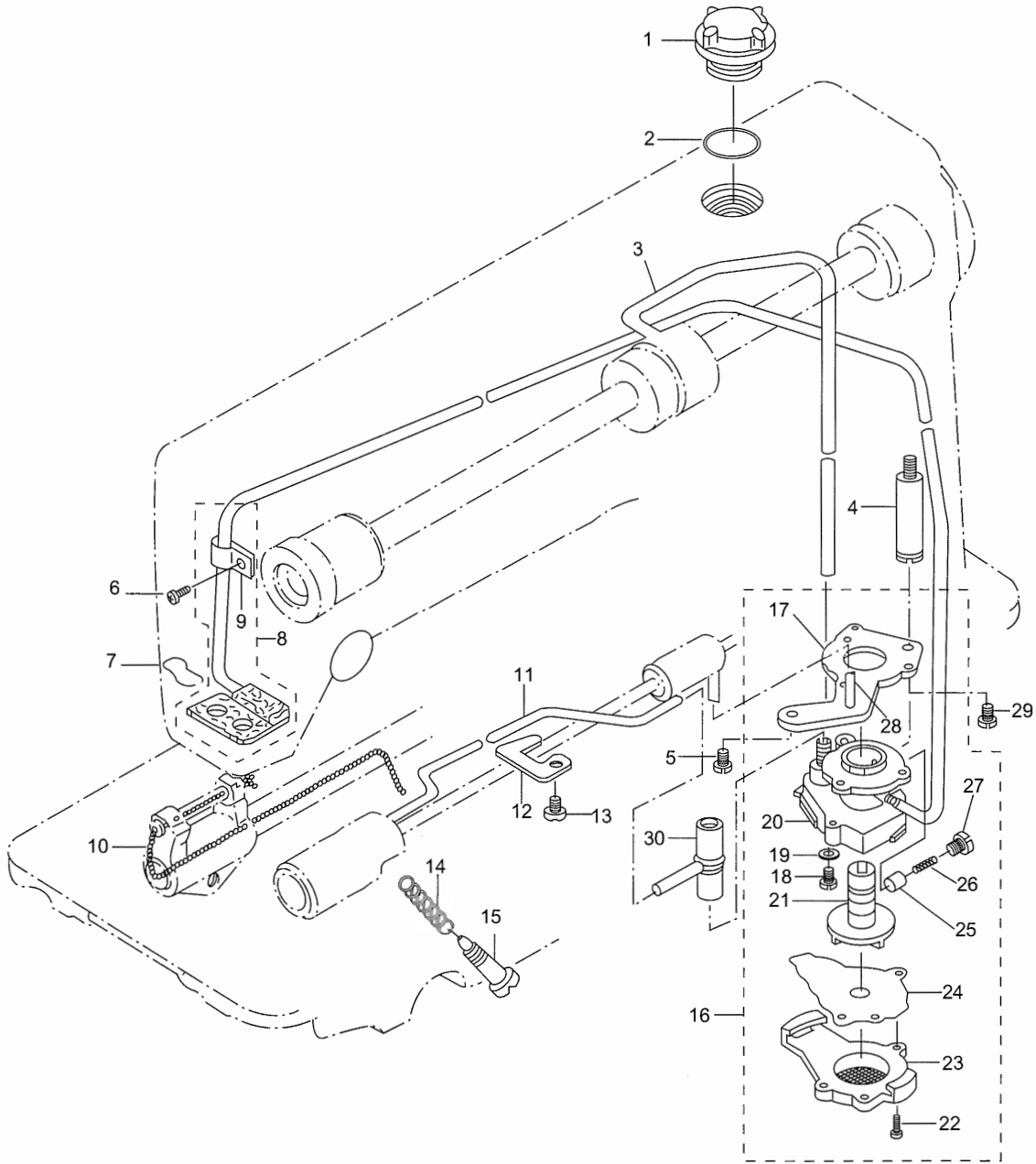

From the library of: Diamond Needle Corp

## 6. LUBRICATION COMPONENTS

No.	P/N	DESCRIPTION	QTY	2 0 0 A	3 0 0 A	3 0 8 A	5 0 8 A
1	IP07015	OIL SIGHT WINDOW	1	☆	☆	☆	☆
2	IP07016	RUBBER RING	1	☆	☆	☆	☆
3	IP04049	ARM SHAFT OIL TUBE	1	☆	☆	☆	☆
4	IP12089	OIL PUMP SUPPORT	1	☆	☆	☆	☆
5	IP12090	SCREW SM15/64"x28 L=9	1	☆	☆	☆	☆
6	IP12091	SCREW SM3/16"x28 L=6	1	☆	☆	☆	☆
7	IP04050	OIL FELT PRESSER	1	☆	☆	☆	☆
8	IP17014	OIL RETURN TUBE ASM.	1	☆	☆	☆	☆
9	IP04051	HOLDER	(1)	☆	☆	☆	☆
10	IP18004	OIL WICK	1	☆	☆	☆	☆
11	IP04052	OIL TUBE	1	☆	☆	☆	☆
12	IP04053	TUBE HOLDER, LOWER	1	☆	☆	☆	☆
13	IP12092	SCREW SM15/64"x28 L=9	1	☆	☆	☆	☆
14	IP10015	SPRING	1	☆	☆	☆	☆
15	IP12093	OIL ADJUSTING SCREW	1	☆	☆	☆	☆
16	IP17015	OIL PUMP ASM.	1	☆	☆	☆	☆
17	IP07017	OIL PUMP INSTALLING BASE	(1)	☆	☆	☆	☆
18	IP12094	SCREW M3X8	(3)	☆	☆	☆	☆
19	IP12218	WASHER	(3)	☆	☆	☆	☆
20	IP07018	OIL PUMP	(1)	☆	☆	☆	☆
21	IP07019	OIL PUMP IMPELLER	(1)	☆	☆	☆	☆
22	IP12095	SCREW	(3)	☆	☆	☆	☆
23	IP07020	OIL PUMP COVER	(1)	☆	☆	☆	☆
24	IP07021	OIL PUMP IMPELLER COVER	(1)	☆	☆	☆	☆
25	IP04054	PLUNGER	(1)	☆	☆	☆	☆
26	IP10016	PLUNGER SPRING	(1)	☆	☆	☆	☆
27	IP12096	PLUNGER SCREW	(1)	☆	☆	☆	☆
28	IP04055	HOOK DRIVING SHAFT OIL TUBE	(1)	☆	☆	☆	☆
29	IP12097	SCREW SM11/64"x40 L=9.5	1	☆	☆	☆	☆
30	IP07022	OIL TUBE JOINT	1	☆	☆	☆	☆

# 7. OIL PAN COMPONENTS

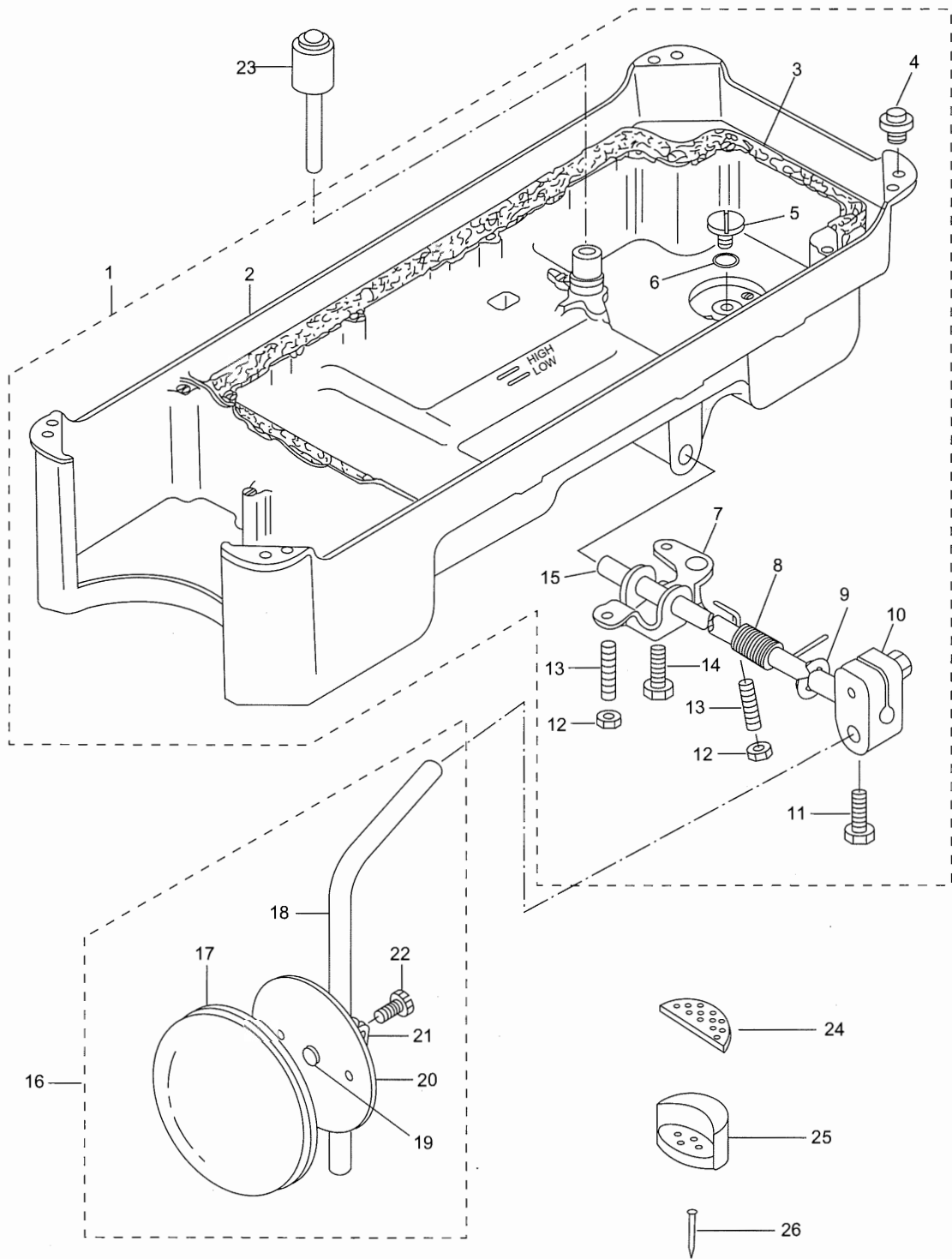



## 7. OIL PAN COMPONENTS

No.	P/N	DESCRIPTION	QTY	200A	300A	308A	508A
1	IP16003	OIL PAN ASM.	1	☆	☆	☆	☆
2	IP17003	OIL PAN	(1)	☆	☆	☆	☆
3	IP07024	GASKET	(1)	☆	☆	☆	☆
4	IP07025	RUBBER GUSHION	(1)	☆	☆	☆	☆
5	IP12098	SCREW	(4)	☆	☆	☆	☆
6	IP07026	RUBBER RING	(1)	☆	☆	☆	☆
7	IP04057	LEVER	(1)	☆	☆	☆	☆
8	IP10017	SPRING	(1)	☆	☆	☆	☆
9	IP12099	SNAP RING	(1)	☆	☆	☆	☆
10	IP05019	BRACKET	(1)	☆	☆	☆	☆
11	IP12100	SCREW SM9/32"x20 L=20	(1)	☆	☆	☆	☆
12	IP12101	NUT SM15/64"x28	(1)	☆	☆	☆	☆
13	IP12102	SCREW SM15/64"x20 L=30	(2)	☆	☆	☆	☆
14	IP12103	SCREW	(2)	☆	☆	☆	☆
15	IP08060	KNEE PRESSING SHAFT	(1)	☆	☆	☆	☆
16	IP17016	KNEE PRESSING PLATE ASM.	1	☆	☆	☆	☆
17	IP07027	KNEE PRESSING PLATE COVER	(1)	☆	☆	☆	☆
18	IP04058	KNEE PRESSING PLATE ROD	(1)	☆	☆	☆	☆
19	IP07028	KNEE PRESSING PLATE RUBBER	(1)	☆	☆	☆	☆
20	IP04059	KNEE PRESSING PLATE	(1)	☆	☆	☆	☆
21	IP04060	KNEE PRESSING PLATE HOLDER	(1)	☆	☆	☆	☆
22	IP12104	SCREW SM15/64"x28 L=15	(1)	☆	☆	☆	☆
23	IP07023	TOP PIN OF LIFTING PRESSER FOOT	1	☆	☆	☆	☆
24	IP07029	OIL PAN CUSHION	2	☆	☆	☆	☆
25	IP07030	OIL PAN SEAT	2	☆	☆	☆	☆
26	IP04061	OIL PAN SEAT NAIL	4	☆	☆	☆	☆

# 8. BELT COVER, BOBBIN WINDER AND THREAD STAND COMPONENTS

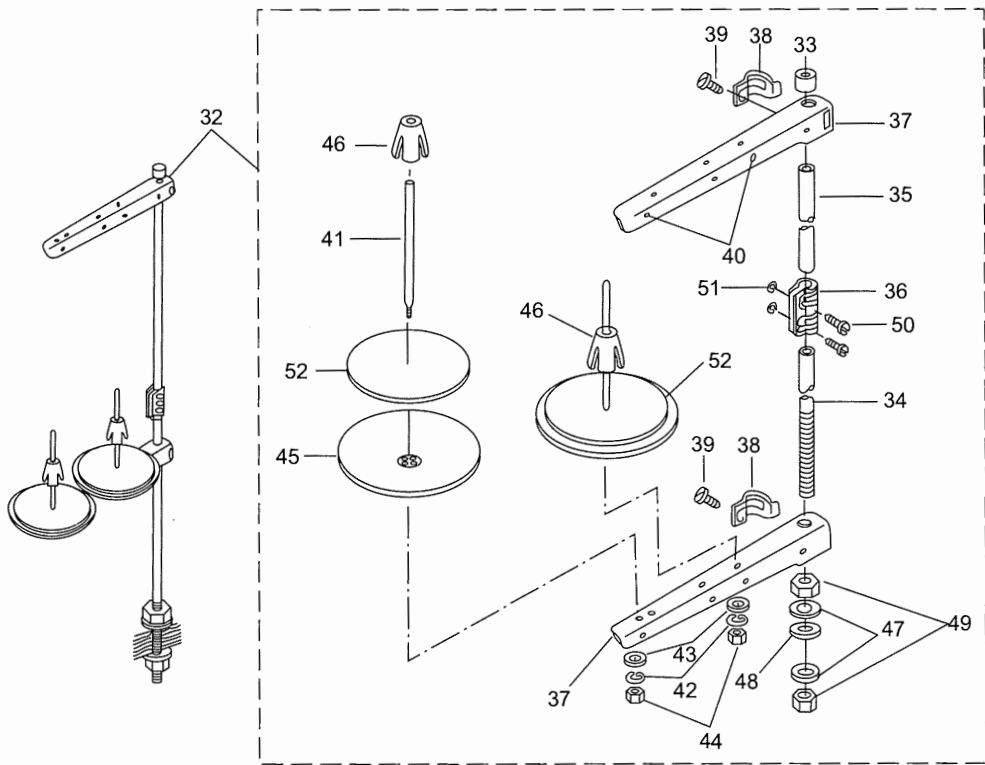
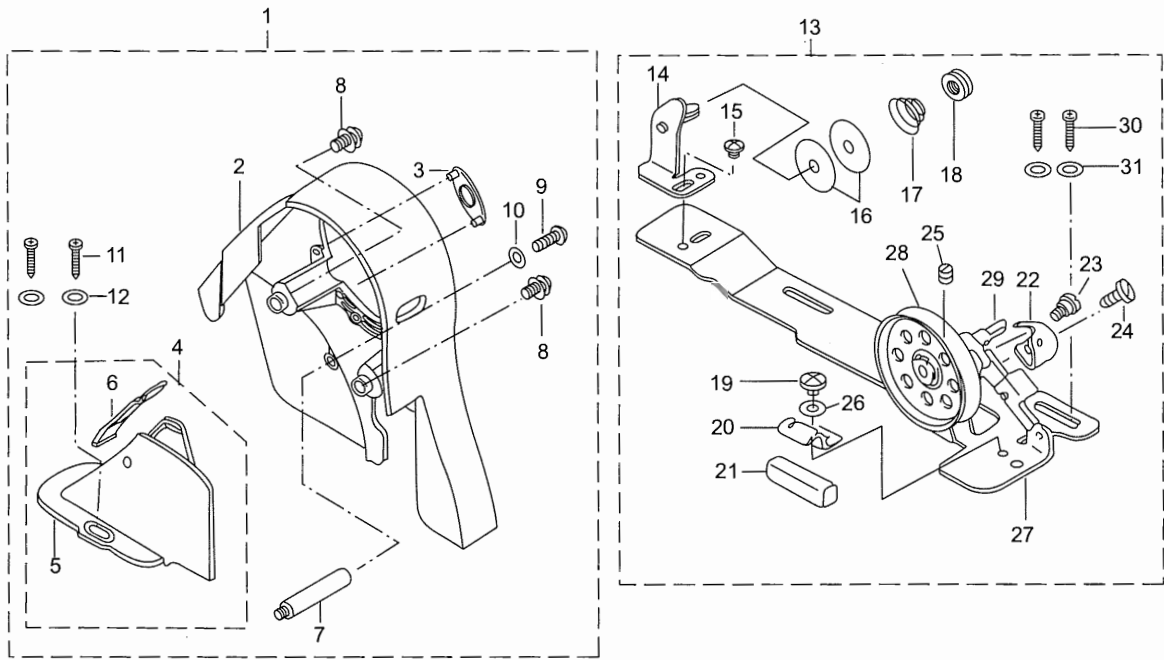

## 8. BELT COVER, BOBBIN WINDER AND THREAD STAND COMPONENTS

No.	P/N	DESCRIPTION	QTY	2 0 0 A	3 0 0 A	3 0 8 A	5 0 8 A
1	IP17002	BELT COVER ASM.	1	☆	☆	☆	☆
2	IP07031	BELT COVER	(1)	☆	☆	☆	☆
3	IP07032	BELT COVER CAP	(1)	☆	☆	☆	☆
4	IP17018	BELT COVER ASM.	(1)	☆	☆	☆	☆
5	IP07033	BELT COVER	(1)	☆	☆	☆	☆
6	IP07034	BELT COVER CAP ASM.	(1)	☆	☆	☆	☆
7	IP12105	BELT COVER SUPPORT	(1)	☆	☆	☆	☆
8	IP12106	BELT COVER SCREW	(2)	☆	☆	☆	☆
9	IP12107	SCREW	(1)	☆	☆	☆	☆
10	IP12108	WASHER	(1)	☆	☆	☆	☆
11	IP12109	SCREW	(2)	☆	☆	☆	☆
12	IP12110	WASHER	(2)	☆	☆	☆	☆
13	IP17019	BOBBIN WINDER COMP.	1	☆	☆	☆	☆
14	IP17020	THREAD TENSION BRACKET	(1)	☆	☆	☆	☆
15	IP12111	SCREW SM11/64"x40 L=7.8	(1)	☆	☆	☆	☆
16	IP04062	TENSION DISK	(2)	☆	☆	☆	☆
17	IP10018	TENSION SPRING	(1)	☆	☆	☆	☆
18	IP12112	TENSION NUT	(1)	☆	☆	☆	☆
19	IP12113	SCREW SM11/64"x40 L=5	(1)	☆	☆	☆	☆
20	IP04063	RUBBER BRAKE RETAINER	(1)	☆	☆	☆	☆
21	IP07035	RUBBER BRAKE	(1)	☆	☆	☆	☆
22	IP10019	POSITIONING FINGER	(1)	☆	☆	☆	☆
23	IP12114	HINGE SCREW SM1/8"x44 L=12.5	(1)	☆	☆	☆	☆
24	IP12115	SCREW	(1)	☆	☆	☆	☆
25	IP12116	SCREW	(1)	☆	☆	☆	☆
26	IP12117	WASHER	(1)	☆	☆	☆	☆
27	IP04064	BOBBIN WINDER BASE	(1)	☆	☆	☆	☆
28	IP04065	BOBBIN PULLEY	(1)	☆	☆	☆	☆
29	IP08061	BOBBIN WINDER POST	(1)	☆	☆	☆	☆
30	IP12118	SCREW	(2)	☆	☆	☆	☆
31	IP12119	WASHER	(2)	☆	☆	☆	☆
32	IP17001	THREAD STAND ASM.	1	☆	☆	☆	☆
33	IP07036	RUBBER CAP	(1)	☆	☆	☆	☆
34	IP08062	SPOOL POST, LOWER	(1)	☆	☆	☆	☆
35	IP08063	SPOOL POST, UPPER	(1)	☆	☆	☆	☆
36	IP04066	SPOOL POST JOINT	(1)	☆	☆	☆	☆
37	IP04067	SPOOL ARM	(2)	☆	☆	☆	☆
38	IP04068	THREAD GUIDE ARM JOINT	(2)	☆	☆	☆	☆
39	IP12120	SCREW	(2)	☆	☆	☆	☆
40	IP07037	THREAD GUIDE	(2)	☆	☆	☆	☆
41	IP04069	SPOOL PIN	(2)	☆	☆	☆	☆
42	IP12121	SPRING WASHER	(2)	☆	☆	☆	☆
43	IP12122	WASHER	(2)	☆	☆	☆	☆
44	IP12123	NUT	(2)	☆	☆	☆	☆
45	IP07038	SPOOL REST	(2)	☆	☆	☆	☆
46	IP07039	SPOOL RETAINER	(2)	☆	☆	☆	☆
47	IP12124	WASHER	(2)	☆	☆	☆	☆
48	IP12125	SPRING WASHER	(1)	☆	☆	☆	☆
49	IP12126	NUT	(2)	☆	☆	☆	☆
50	IP12127	SCREW	(2)	☆	☆	☆	☆
51	IP12128	NUT	(2)	☆	☆	☆	☆
52	IP07040	SPOOL REST CUSHION	(2)	☆	☆	☆	☆

# 9. ACCESSORY PARTS

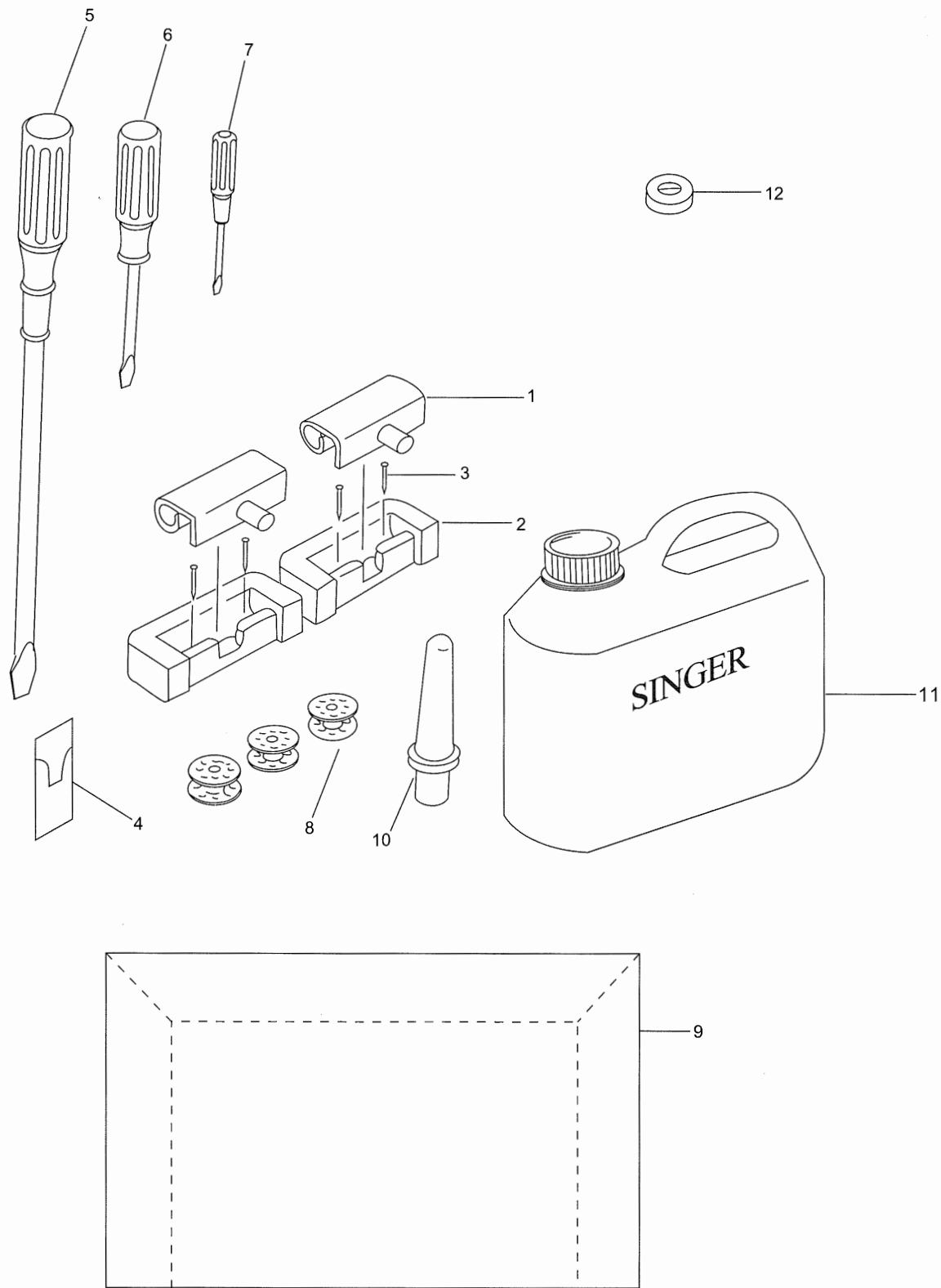

From the library of: Diamond Needle Corp

## 9. ACCESSORY PARTS

No.	P/N	DESCRIPTION	QTY	2 0 0 A	3 0 0 A	3 0 8 A	5 0 8 A
1	IP04074	MACHINE HEAD CONNECTING HOOK	2	☆	☆	☆	☆
2	IP07041	MACHINE HEAD CONNECTING HOOK SEAT	2	☆	☆	☆	☆
3	IP04075	SEAT NAIL	4	☆	☆	☆	☆
4	1955-01 size14	MACHINE NEEDLE	1	☆			
	1955-01 size16	MACHINE NEEDLE	1		☆		
	1955-01 size21	MACHINE NEEDLE	1			☆	☆
5	IP18005	SCREW DRIVER (L)	1	☆	☆	☆	☆
6	IP18006	SCREW DRIVER (M)	1	☆	☆	☆	☆
7	IP18007	SCREW DRIVER (S)	1	☆	☆	☆	☆
8	IP04076	BOBBIN	3	☆	☆	☆	☆
9	IP07042	MACHINE HEAD COVER	1	☆	☆	☆	☆
10	IP07043	MACHINE HEAD POLE	1	☆	☆	☆	☆
11	IP07044	OIL BOTTLE WITH OIL	1	☆	☆	☆	☆
12	IP18008	OIL PAN MAGNET	1	☆	☆	☆	☆





From the library of: Diamond Needle Corp